

PRODUCT INFORMATION PACKET

marathon[®]
Motors

Model No: 213TTDW16061
Catalog No: U926A
7 1/2, 1800, DP, 213T, 3/60/575
Open Drip Proof (ODP)



Regal and Marathon are trademarks of Regal Beloit Corporation or one of its affiliated companies.
©2018 Regal Beloit Corporation, All Rights Reserved. MC017097E

REGAL[®]



Nameplate Specifications

Output HP	7.50 Hp	Output KW	5.6 kW
Frequency	60 Hz	Voltage	575 V
Current	7.7 A	Speed	1760 rpm
Service Factor	1.15	Phase	3
Efficiency	91 %	Duty	Continuous
Insulation Class	B	Design Code	B
KVA Code	H	Frame	213T
Enclosure	Drip Proof	Overload Protector	Automatic
Ambient Temperature	40 °C	Drive End Bearing Size	6307
Opp Drive End Bearing Size	6206	UL	Recognized
CSA	Y	CE	Y
IP Code	22		

Technical Specifications

Electrical Type	Squirrel Cage Induction Run	Starting Method	Across The Line
Poles	4	Rotation	Reversible
Mounting	Rigid base	Motor Orientation	Horizontal
Drive End Bearing	Ball	Opp Drive End Bearing	Ball
Frame Material	Rolled Steel	Shaft Type	T
Overall Length	19.29 in	Frame Length	12.40 in
Shaft Diameter	1.375 in	Shaft Extension	3.47 in
Assembly/Box Mounting	F1/F2 Capable		
Outline Drawing	A-SS86668-1240	Connection Diagram	A-EE7335B

This is an uncontrolled document once printed or downloaded and is subject to change without notice. Date Created: 06/29/2018

SS86668

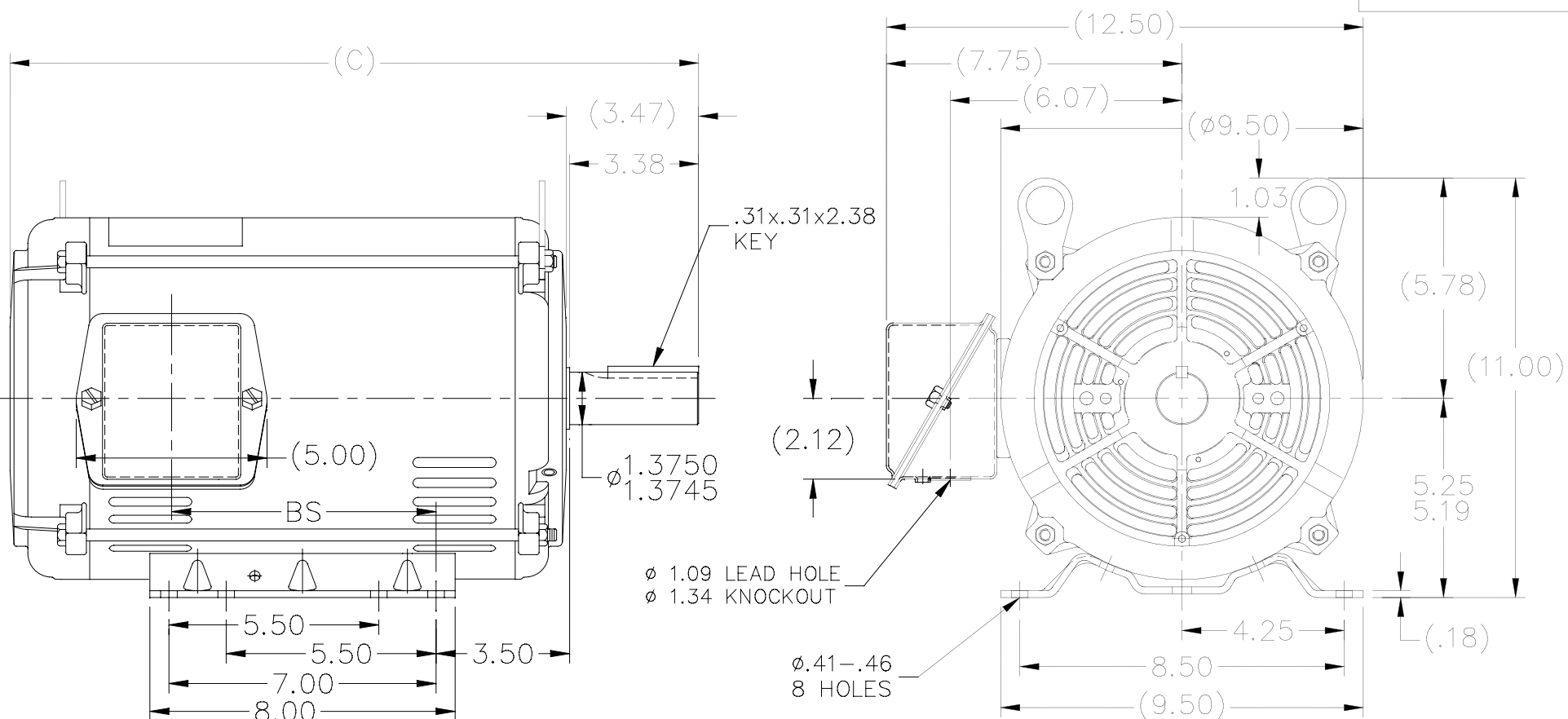

DASH	FR.	C	BS	MOUNTING
965	213T	16.54	5.43	
1115	213/15T	18.04	6.93	
1240	213/15T	19.29	8.18	F1 ONLY
1545	215T	22.34	11.23	F1 ONLY

- NOTES:
1. NAMEPLATE TO BE READ FROM C'BOX SIDE OF MOTOR.
 2. BOX CAN BE MOUNTED IN 90° STEPS.
 3. BOX CAN BE MOUNTED ON OPPOSITE SIDE BY REMOVING BRACKETS AND TURNING FRAME 180°. (EXCEPT AS NOTED.)

06-22-2004

			TOLERANCES UNLESS SPECIFIED		 Regal Beloit America, Inc.	DRAWN MRB 04-03-1997				
			DEC.	INCHES		CHK	ML	04-04-1997		
			.X	±.1						
3	TITLE BLOCK CHANGE PER ECO-0078542	MDV 06/09/2015	.XX	±.03	TITLE OUTLINE			SCALE	1=4	
2	UPDATED C'BOX GEOMETRY CN 28425	BJW 03-24-2000	.XXX	±.005	210T FR. - BB - TS - DR.PR.			REF		
1	NEW DRAWING	MRB 04-04-1997	.XXXX	±.0005	MAT'L.			FMF		
NO.	REVISION	BY & DATE	CHK	ANG	FINISH	PREV				
			RFP		CAD FILE SS86668		SIZE	DRAWING NO.	PAGE OF	REV.
			DIST	LB			A	SS86668		3

THIS DRAWING IN DESIGN AND DETAIL IS OUR PROPERTY AND MUST NOT BE USED EXCEPT IN CONNECTION WITH OUR WORK ALL RIGHTS OF DESIGN AND INVENTION ARE RESERVED THIS IS AN ELECTRONICALLY GENERATED DOCUMENT - DO NOT SCALE THIS PRINT

SINGLE VOLTAGE – THREE PHASE WITH OVERLOAD PROTECTOR

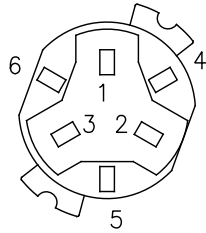

NOTE:
ACTUAL PROTECTOR
TERMINAL LOCATIONS
FOR LEAD CONNECTIONS

NOTE:

WEST PLAINS

LEADS WITH TERMINALS
SHOULD BE CONNECTED
TO INBOARD SIDE OF
TERMINAL BOARD.

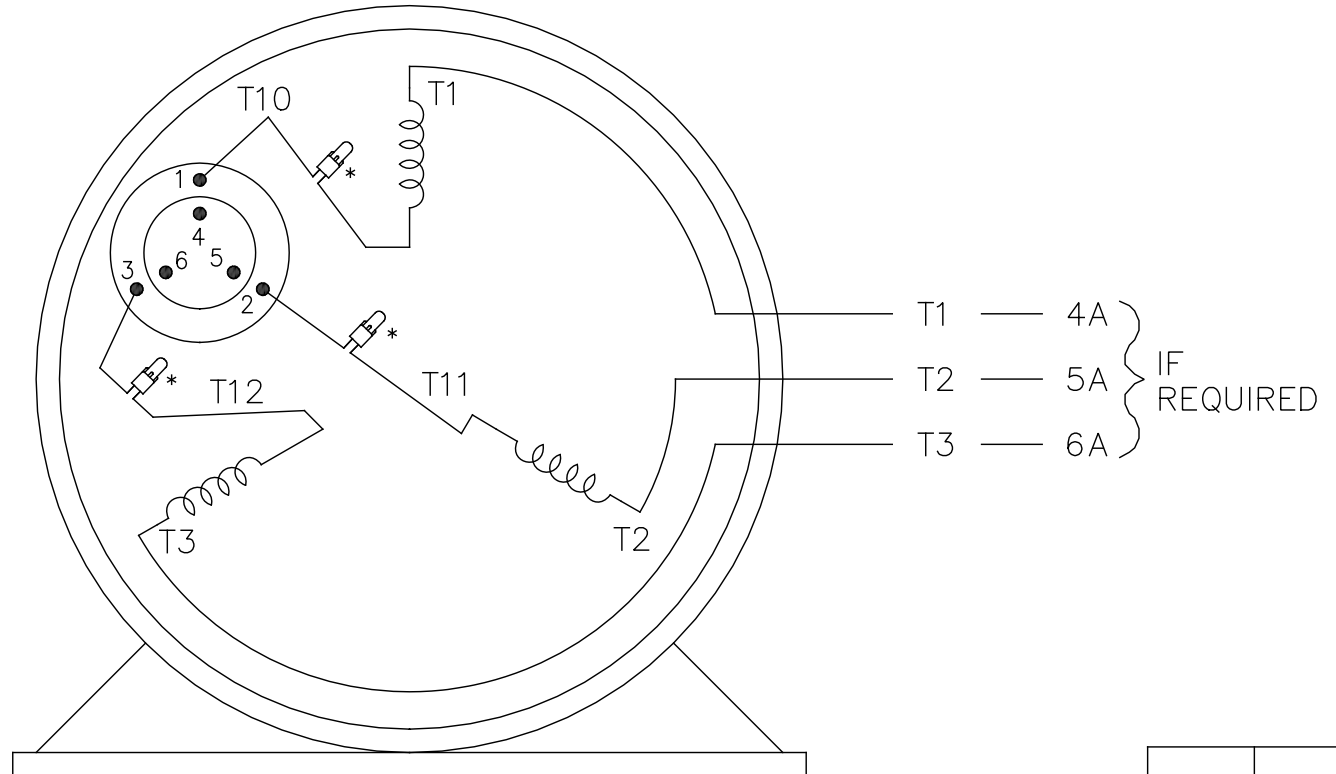

VIEW OF TERMINAL END

OPTIONAL CORD
CONNECTION

L1 WHITE

L2 RED

L3 BLACK

		T6CK
T6CA	T6BM	
T4CC	T4AY	
T4C	T2DL	
T6D	T2H	

–TO REVERSE ROTATION–
INTERCHANGE ANY TWO
LINE LEAD CONNECTIONS

* USE PRESSURE CONNECTORS FOR MT2 PLANT ONLY

NO.	REVISION	BY & DATE	CHK	ANG	±	–	FINISH	PREV
11	ADDED THE OPTIONAL CORD CONNECTION	JAH 11-12-2014	RD					
10	PRESSURE CONNECTORS ADDED (QTY 3)	PVR 07-09-2014	GR					
9	ADDED 4A, 5A, & 6A "IF REQUIRED" MU44987	MSG 01-07-2002	SAS	.X	±	–		
8	ADDED ACTUAL PROTECTOR VIEW CN 17481	KL 05-18-1994		.XX	±	–	TITLE CONNECTION DIAGRAM	SCALE 1=1
7	REWORDED WEST PLAINS NOTE – PER WEST PLAINS	DD 01-12-1994		.XXX	±	–	SINGLE VOLT – 3Ø WITH OVERLOAD PROT.	REF
6	REDRAWN ON CAD – "WEST PLAINS" NOTE ADDED	KL 08-26-1993		.XXXX	±	–	MAT'L.	FMF



THIS DRAWING IN DESIGN AND DETAIL IS OUR PROPERTY AND MUST NOT BE USED EXCEPT
IN CONNECTION WITH OUR WORK ALL RIGHTS OF DESIGN AND INVENTION ARE RESERVED
THIS IS AN ELECTRONICALLY GENERATED DOCUMENT – DO NOT SCALE THIS PRINT

RFP	CAD FILE EE7335B	SIZE A	DRAWING NO. EE7335B	PAGE OF	REV. 11
DIST LB-WP					

CERTIFICATION DATA SHEET

Model#: 213TTDW16061 AA **WINDING#:** K2134182 NONE 6
CONN. DIAGRAM: A-EE7335B **ASSEMBLY:** F1/F2 CAPABLE
OUTLINE: A-SS86668-1240

TYPICAL MOTOR PERFORMANCE DATA

HP	KW	SYNC. RPM	F.L. RPM	FRAME	ENCLOSURE	KVA CODE	DESIGN			
7 1/2	5.60	1800	1760	213T	DP	H	B			
PH	Hz	VOLTS	FL AMPS	START TYPE	DUTY	INSL	S.F	AMB°C	ELEVATION	
3	60	575	7.7	ACROSS THE LINE	CONTINUOUS	B3	1.15	40	3300	
FULL LOAD EFF: 91		3/4 LOAD EFF: 91		1/2 LOAD EFF: 89.7		GTD. EFF		ELEC. TYPE		NO LOAD AMPS
FULL LOAD PF: 80		3/4 LOAD PF: 75		1/2 LOAD PF: 64.8		89.5		SQ CAGE IND RUN		3.3
F.L. TORQUE		LOCKED ROTOR AMPS		L.R. TORQUE		B.D. TORQUE		F.L. RISE°C		
22.5 LB-FT		50.8		51 LB-FT 227		66 LB-FT 293		22		
SOUND PRESSURE @ 3 FT.	SOUND POWER	ROTOR WK^2	MAX. WK^2	SAFE STALL TIME	STARTS /HOUR	APPROX. MOTOR WGT				
66 dBA	76 dBA	0.85 LB-FT^2	50 LB-FT^2	20 SEC.	2	125 LBS.				

***** SUPPLEMENTAL INFORMATION *****

DE BRACKET TYPE	ODE BRACKET TYPE	MOUNT TYPE	ORIENTATION	SEVERE DUTY	HAZARDOUS LOCATION	DRIP COVER	SCREENS	PAINT
STANDARD	STANDARD	RIGID	HORIZONTAL	FALSE	NONE	FALSE	NONE	BLUE (ENAMEL)

BEARINGS		GREASE	SHAFT TYPE	SPECIAL DE	SPECIAL ODE	SHAFT MATERIAL	FRAME MATERIAL
DE	OPE	POLYREX EM	T	NONE	NONE	1144 STRESSPROOF (C-223)	ROLLED STEEL
BALL	BALL						
6307	6206						

THERMO-PROTECTORS				THERMISTORS	CONTROL	SPACE /n HEATERS
THERMOSTATS	PROTECTORS	WDG RTDs	BRG RTDs	NONE	FALSE	NONE VOLTS
NONE	AUTOMATIC	NONE	NONE			

If Inverter equals NONE, contact factory for further information

*
N
O
T
E
S
*

INVERTER TORQUE: NONE
INV. HP SPEED RANGE: NONE
ENCODER: NONE
NONE NONE
NONE NONE PPR
BRAKE: NONE NONE
NONE P/N NONE
NONE NONE
NONE FT-LB NONE V NONE Hz

DATE: 06/22/2017 04:59:05 AM
 FORM 3531 REV.3 02/07/99
 ** Subject to change without notice.

Data Sheet

Date: 15-06-2017
 Customer: _____
 Attention: _____
 Submitted by: FAREEDA DUDEKULA



213TTDW16061
Submittal
 Data @ 575 V

Motor Load Data									
Load	0%	25%	50%	75%	100%	115%	125%	LR	
Current (Amps)	3.3	3.8	4.8	6.2	7.7	8.6	9.6	50.8	
Torque (ft-lb)	0.00	5.5	11.0	16.6	22.5	25.5	28.0	51.0	
RPM	1800	1790	1780	1775	1760	1,755	1752	0	
Efficiency (%)		87.4	89.7	91.0	91.7	90.8	90.5		
P.F. (%)	6.5	41.8	64.8	75.0	81.0	81.4	80.5	39.5	

Motor Speed Data						Information Block	
	LR	Pull-Up	BD	Rated	Idle		
Speed (RPM)	0	700	1605	1760	1800	HP	7.5
Current (Amps)	50.8	44.0	30.0	7.7	3.3	Sync. RPM	1800
Torque (ft-lb)	51.0	40.0	66.0	22.5	0.00	Frame	213

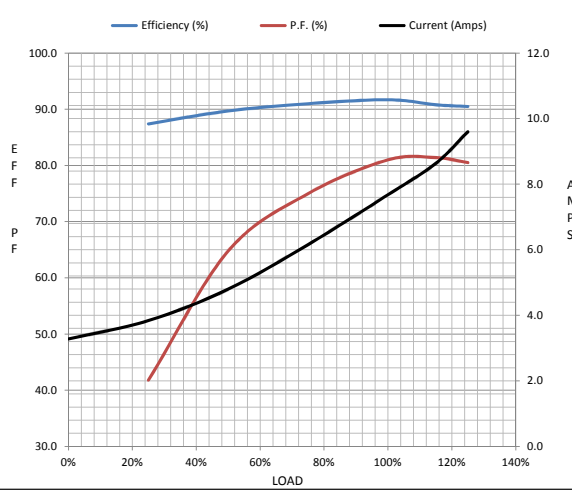

Construction	TDW			
Voltage	575 V			
Frequency	60 Hz			
Design	B			
LR Code letter	H			
Service Factor	1.15			
Temp Rise @ FL	22 ° C			
Duty	CONT			
Ambient	40 ° C			
Elevation	1,000 feet			
Rotor/Shaft wk ²	0.85 Lb-Ft ²			
Ref Wdg	K2134182 NONE			
Sound Pressure @ 1M	66 dBA			
VFD Rating	NONE			
Outline Dwg	A-SS86668-1240			
Conn. Diag	A-EE7335B			
Additional Specifications:				
0				
365THFS8036				
EQUIV CKT (OHMS / PHASE)				
R1	R2	X1	X2	Xm
1.1870	0.8740	4.0750	5.7760	89.7750

